

REVISION HISTORY			
REV	DESCRIPTION	DATE	APPROVED

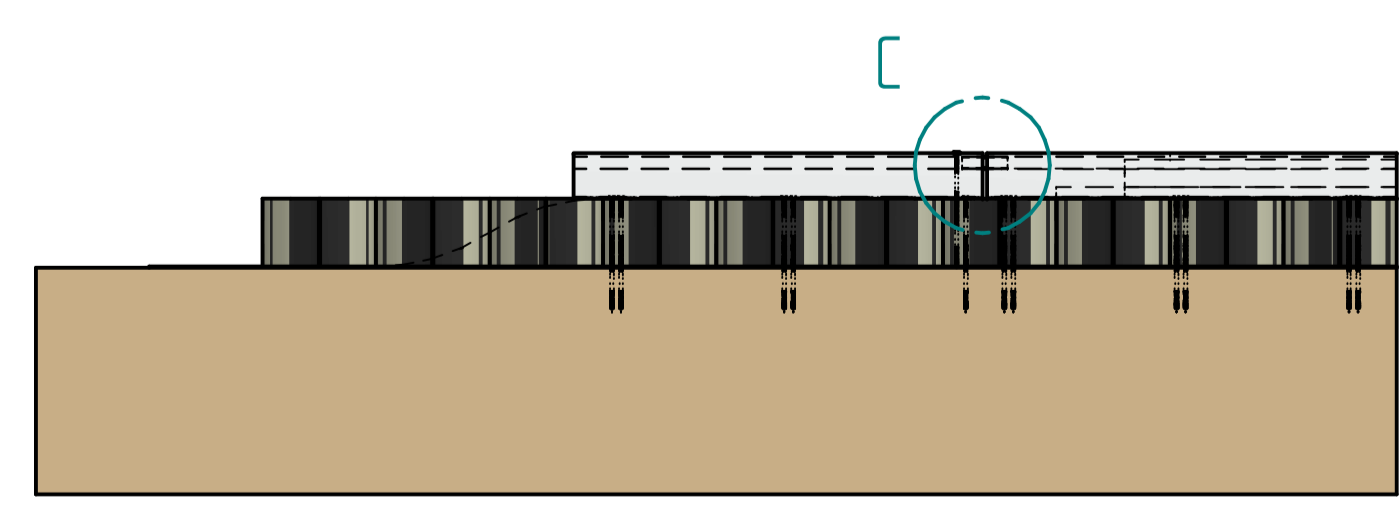
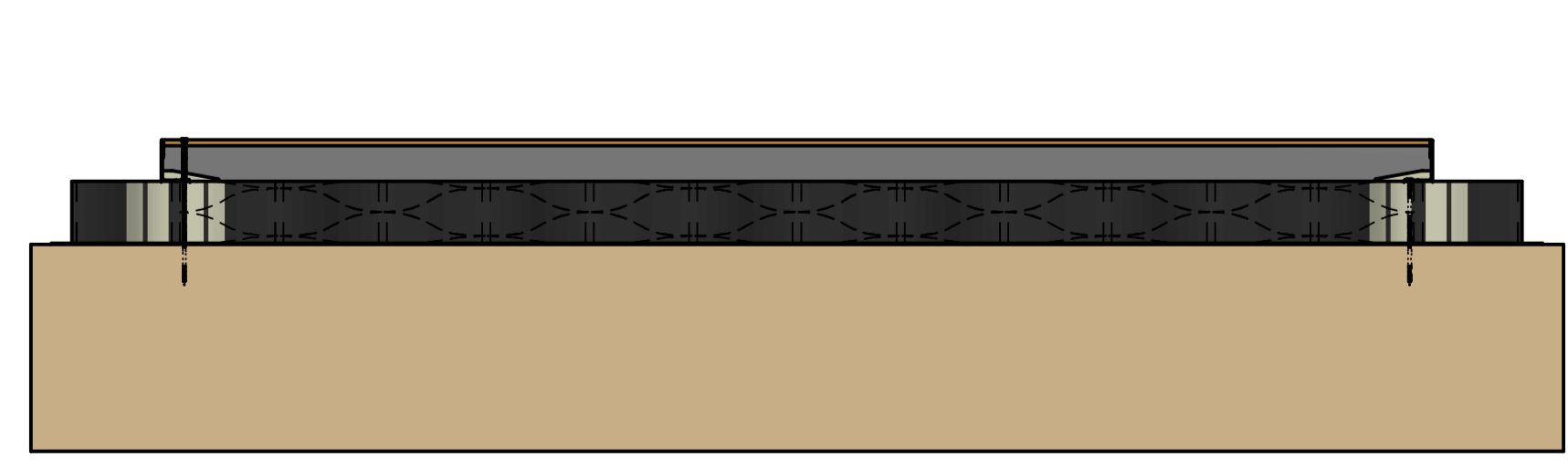
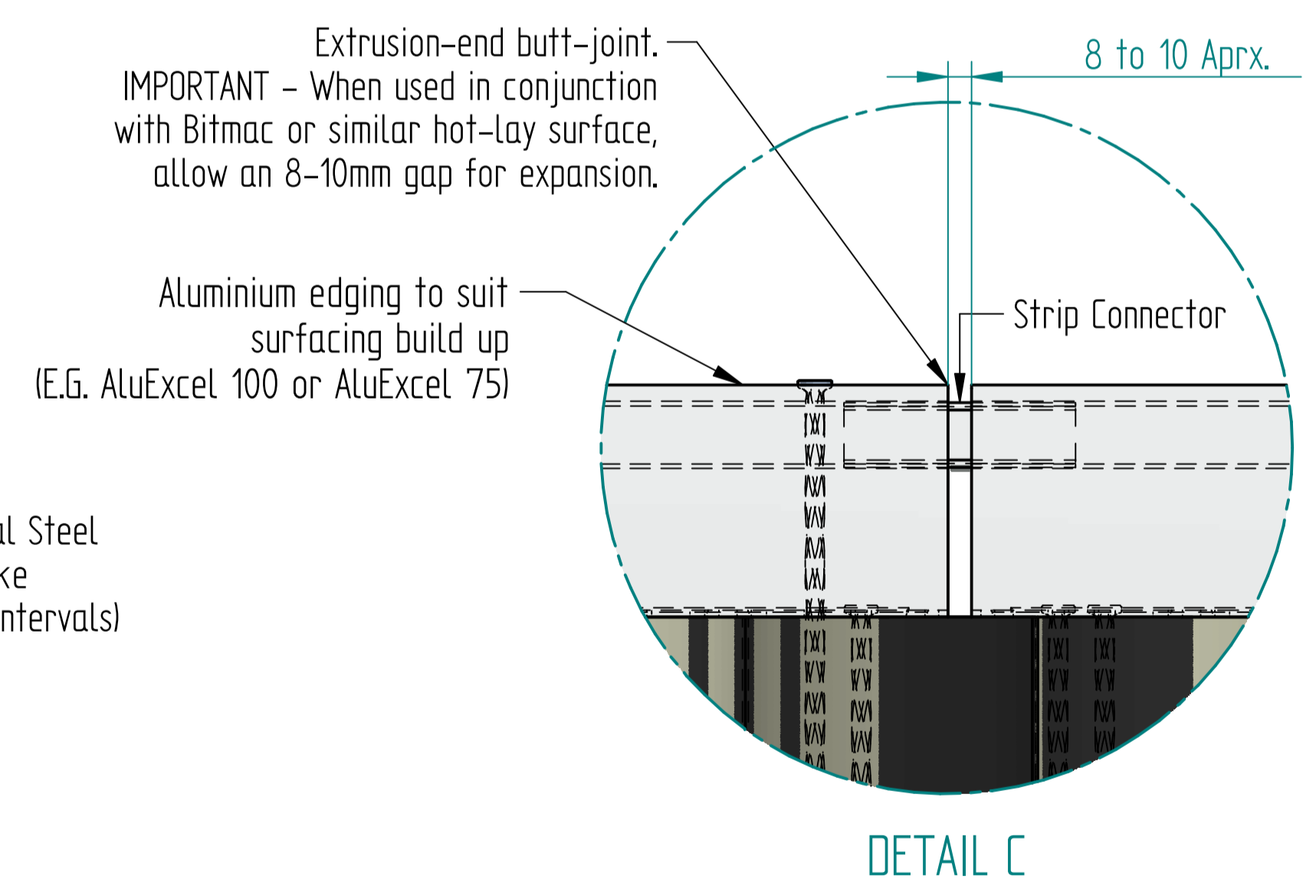
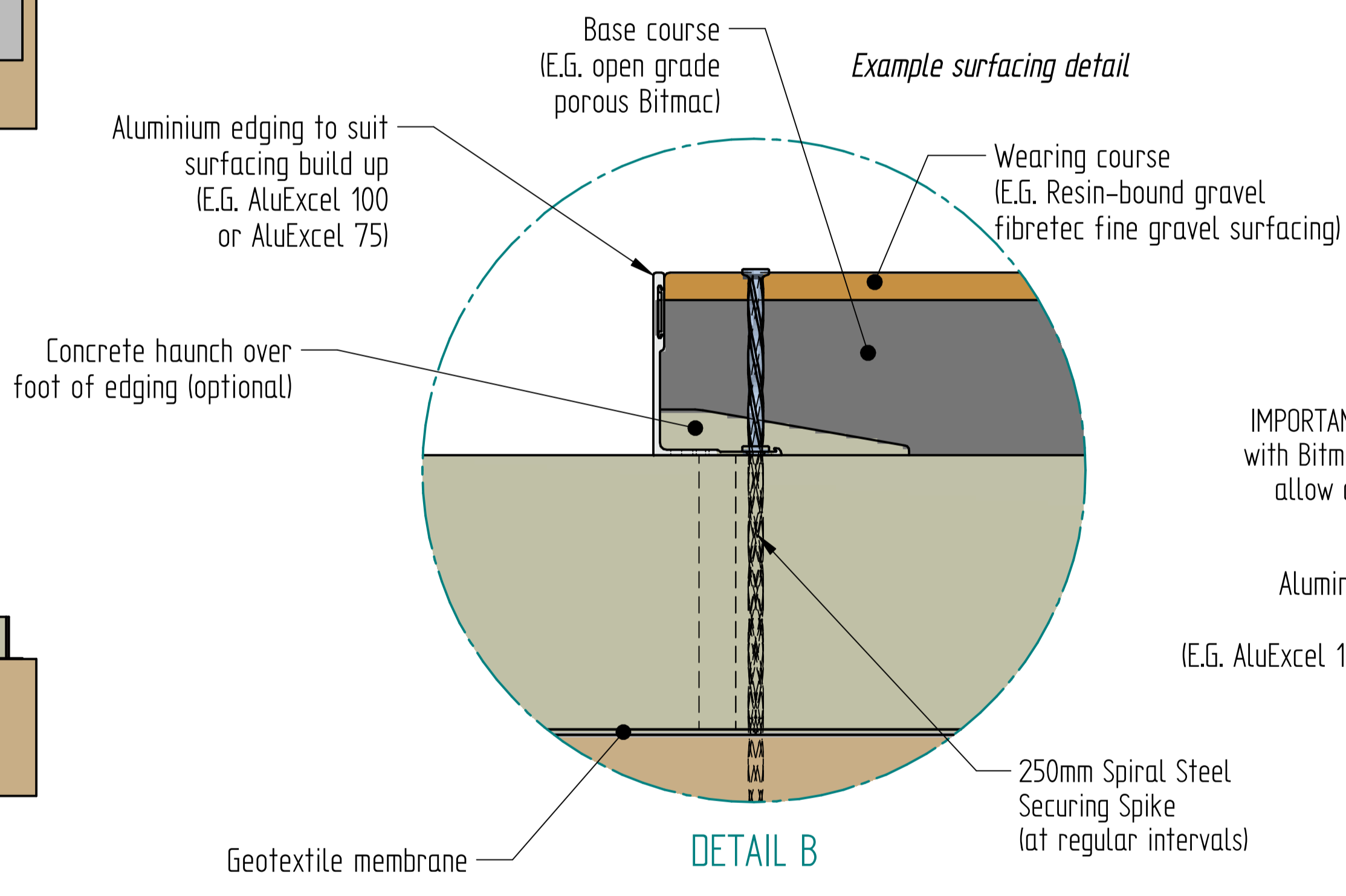
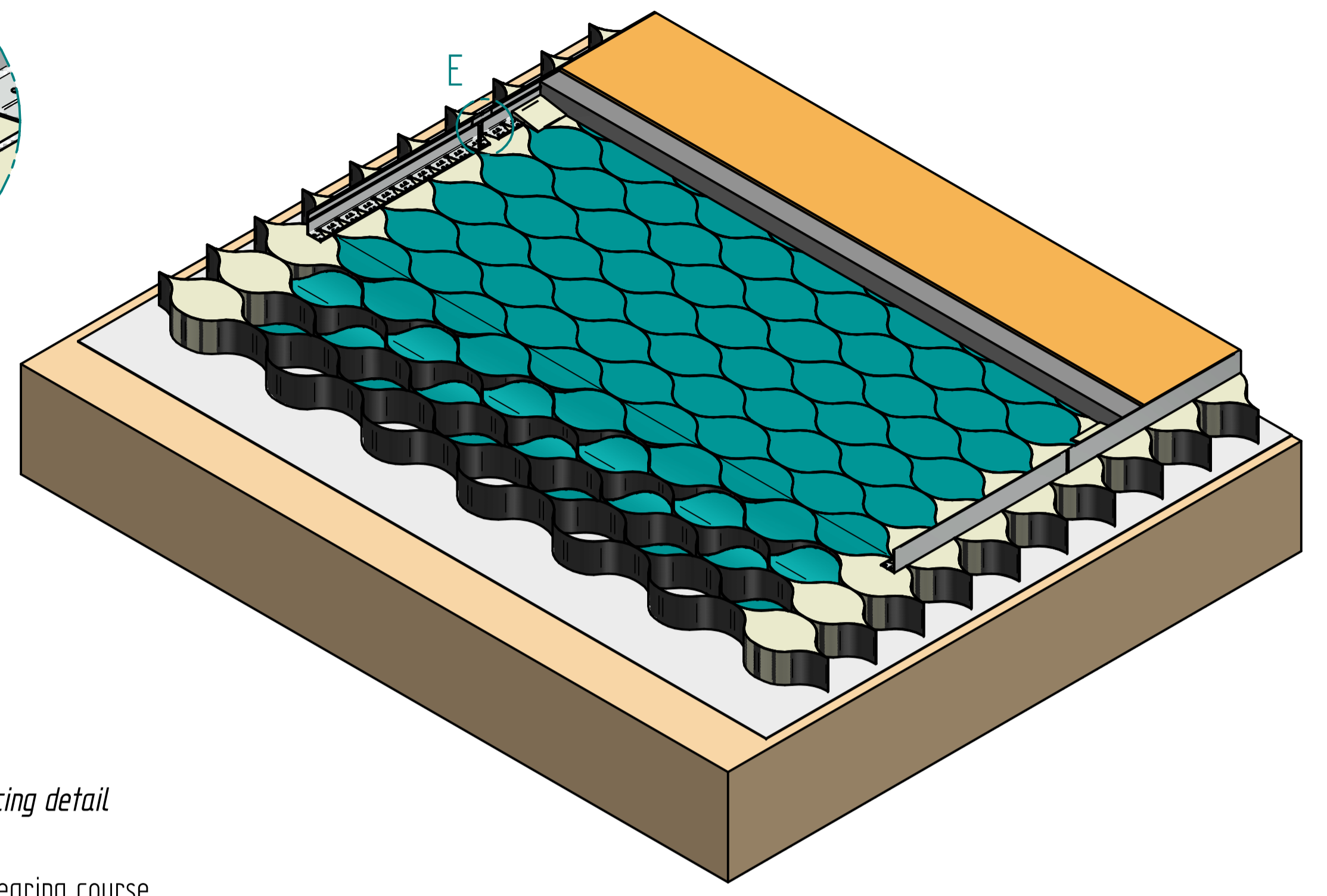
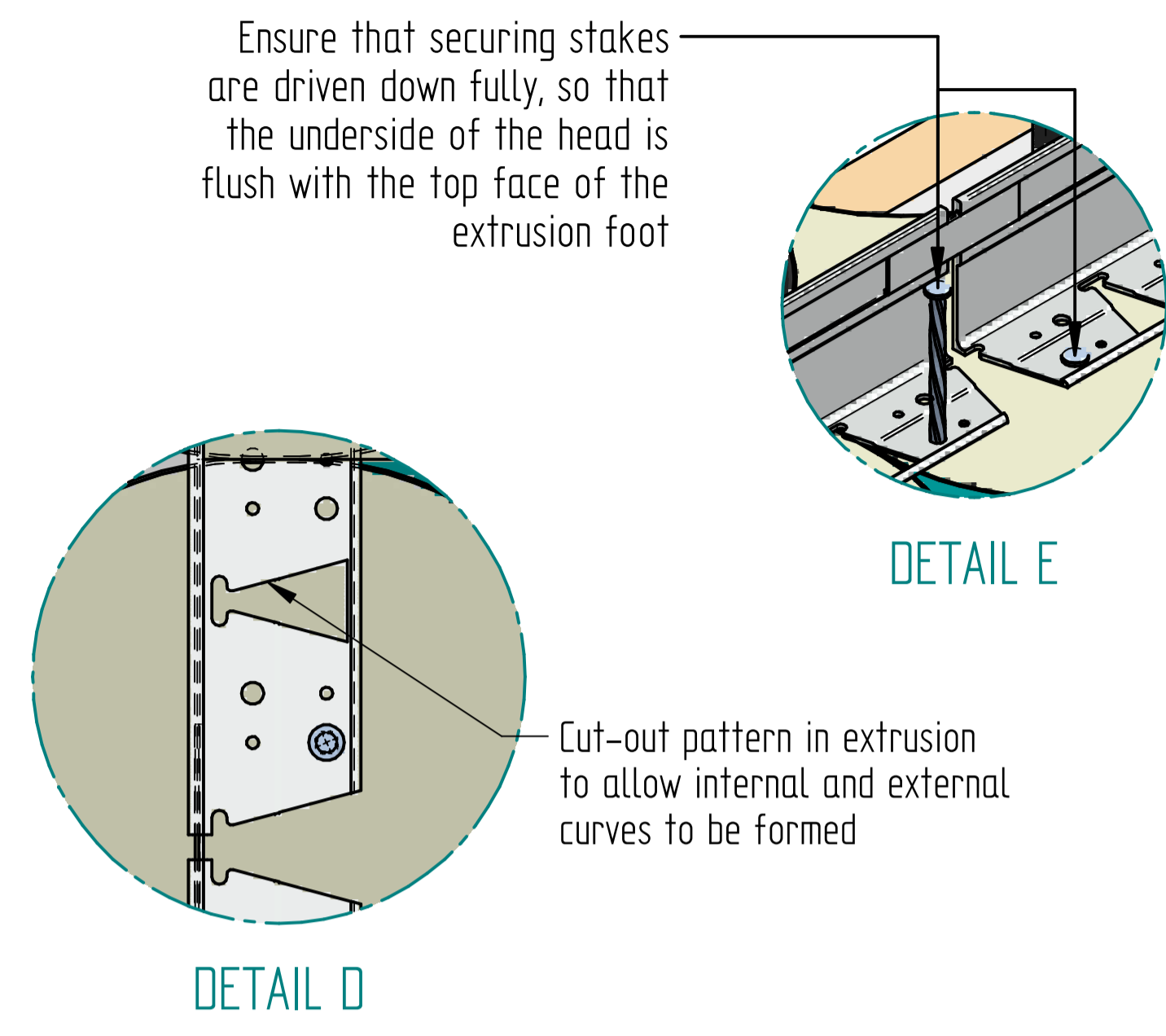
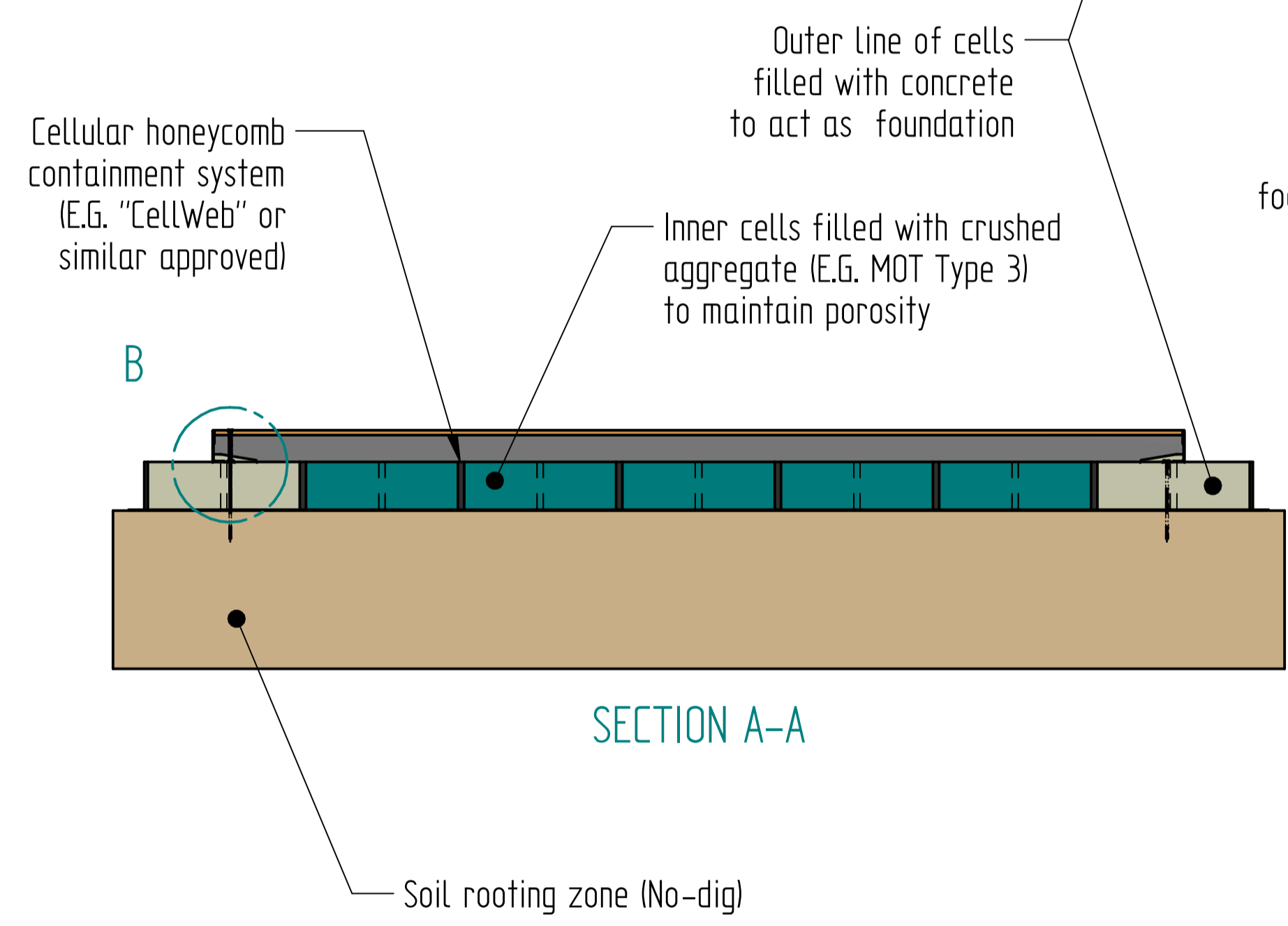
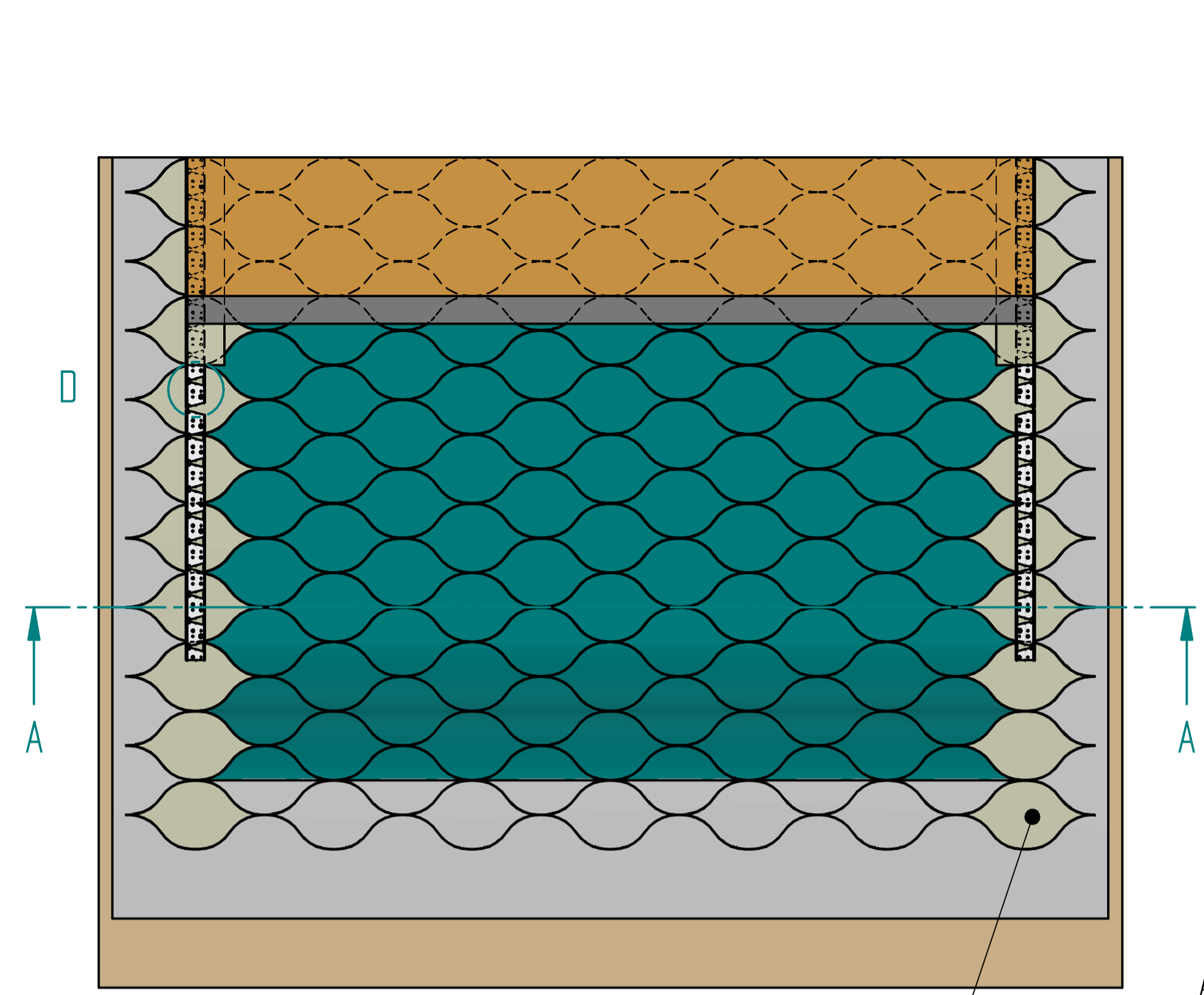

DRAWN	NAME	DATE	Kinley Systems Landscape Edging Solutions	
CHECKED	Adrian White	17/01/2012	3 Hayward Way, Ivyhouse Industrial Estate, Haslemere, East Sussex TN35 4PL Tel: +44 (0)1424 201 111 Fax: +44 (0)1424 205 240 E-mail: sales@kinleysystems.com	
ENG APPR			TITLE	
MGR APPR			Installation Guide	
			AE100 No-dig 1 Installation Guide	
UNLESS OTHERWISE SPECIFIED DIMENSIONS ARE IN MILLIMETERS ANGLES °XX' 2 PL ±XXX 3 PL ±XXXX			SIZE DWG NO	REV
			A1 KIN-11228-DFT-001	B
			FILENAME: AE100_No-Dig1_Installation_Guide.dft	
			SCALE:	WEIGHT: SHEET 1 OF 1